

DATA SHEET

CONTINUOUS GAS FRYER

FGC250

Continuous gas fryer or frying train ideal for a large production automatically, having the minimum use of labor and with high productivity. This chain fryer is designed for pre-fried, fried potatoes, fried foods such as croquettes, marble foods, flamenquines, nuggests, cachopo, plate of ham and cheese,...,pastry products in general such as: churro, fritter, doughnut, xuixo, donut, creme filled pastry... Nuts: peanut, almonds, cashews,... Even pasta cooking. Being very easy to clean and use, thaks to the oil circulation pump equipped with a filter, in which the used oil that is stored in the storage tank is automatically filtered and sent clean to the filter tank.

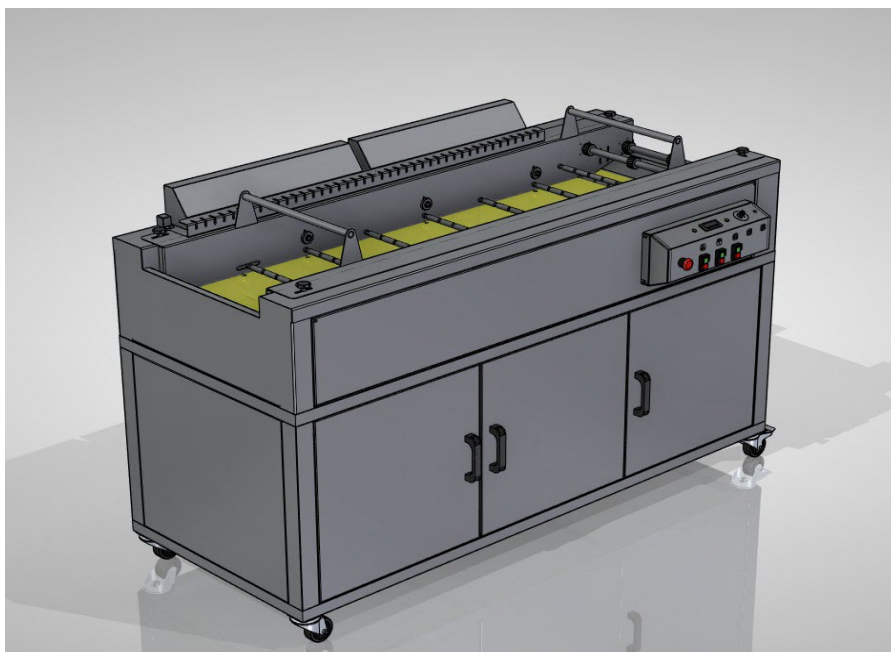

TECHNICAL SPECIFICATIONS:

- It incorporates a speed variator that allows the regulation of the cooking time of the product that is made, with the intention that it always has the ideal cooking time and adapted to an infinity of products.
- It allows a homogeneous frying or cooking, with less oil absorption at a lower cost thanks to the reuse and filtering of the oil. Thanks to this, the oil is more durable and of higher quality.
- Optional availability of including extraction hood in the fryer itself.
- Easy cleaning and disassembly.
- Oil filtering system by means of a re-circulating pump to the tank.
- Digital temperature control.
- Built in AISI304.
- Is incorporates a pump for filling the tank.
- Resettable safety thermostat with warning light.
- 2" drain tap.
- Tensioners in conveyor chains.

MODELO: FGC250

DIMENSIONS: WIDTH 953 mm. / HEIGHT 1255 mm. / LONG 5003mm.

DUAL BURNER POWER: GN/GLP/OIL : 40X5(200) KW GLP G 30 **FLOW RATE** 0,37 Mb **PRESSURE** 4 kg/h

CHAIN MOTOR POWER: 1,1 KW.

PUMP MOTOR POWER: 1 KW.

TOTAL POWER:150 KW

TENSION: 220/240 FRECUENCIA 50 HZ.

PRODUCCION: 240kg/h a 1600 Kg/h.*

BELT WIDTH: 440 cm.

DIMENSIONS

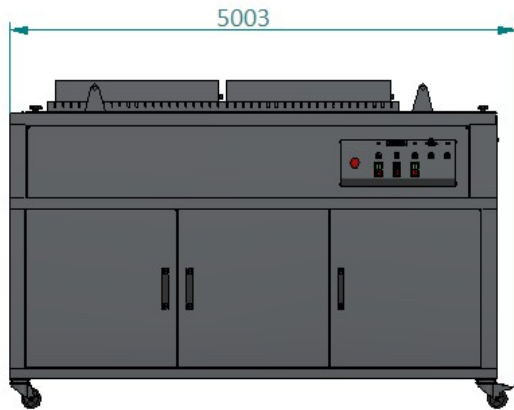

VISTA FRONTAL

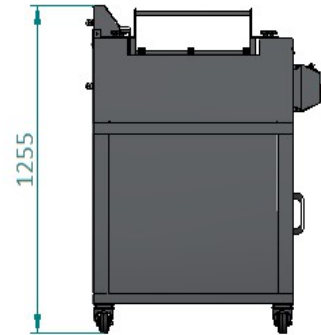

VISTA LATERAL

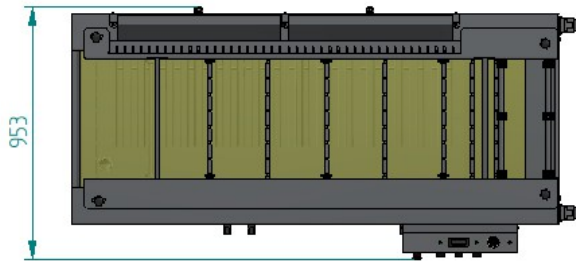

VISTA PLANTA

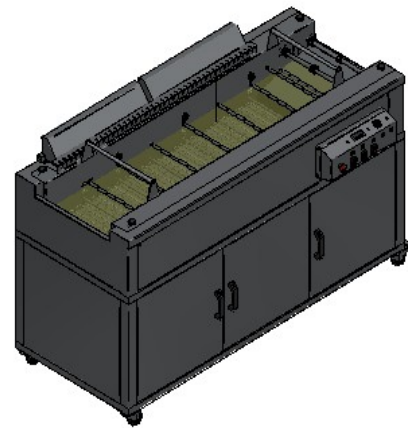

VISTA ISOMÉTRICA

APPROXIMATE WEIGHT. 1100Kg.
ELECTRIC CONNECTION: 220/240 V, 50/60

The Company reserves the right to make technical modifications without notice.

www.inhospa.com

V1,0 - 2021/02/03

*Production rates can vary significantly depending on the temperature, the size of the pieces, or the type of food being fried.